

ARI-FABA® Long Life - Stop valve with bellows seal, maintenance-free

**ARI-FABA® Long Life
Straight through with flanges**

- DIN-DVGW-registration
- Test approvals TÜ.A/TÜV.AR.186-00
- German "TA-Luft" TÜV-Test-No. 088-945053
- TRB 801 No. 45 (except cast iron)

Cast iron
Nodular iron
Cast steel
Forged steel
BR 046

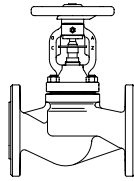

Page 2

**ARI-FABA® Long Life
Straight through with butt weld ends**

- DIN-DVGW-registration
- Test approvals TÜ.A/TÜV.AR.186-00
- German "TA-Luft" TÜV-Test-No. 088-945053
- TRB 801 No. 45

Forged steel
BR 040

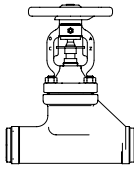

Page 3

**ARI-FABA® Long Life
Straight through with butt weld ends**

- DIN-DVGW-registration
- Test approvals TÜ.A/TÜV.AR.186-00
- German "TA-Luft" TÜV-Test-No. 088-945053
- TRB 801 No. 45

Cast steel
BR 040

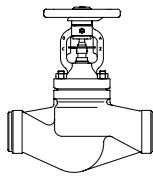

Page 3

**ARI-FABA® Long Life Y-pattern
Straight through with butt weld ends**

- DIN-DVGW-registration
- Test approvals TÜ.A/TÜV.AR.186-00
- German "TA-Luft" TÜV-Test-No. 088-945053
- TRB 801 No. 45

Cast steel
BR 066

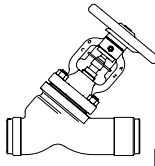

Page 4

**ARI-FABA® Long Life Angle pattern
Straight through with flanges**

- DIN-DVGW-registration
- Test approvals TÜ.A/TÜV.AR.186-00
- German "TA-Luft" TÜV-Test-No. 088-945053
- TRB 801 No. 45 (except cast iron)

Cast iron
Nodular iron
Cast steel
BR 047

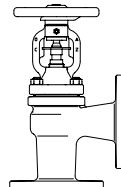

Page 4

**ARI-FABA® LA Straight through
with long bellow & flanges**

- German "TA-Luft" TÜV-Test-No. 088-945053
- TRB 801 No. 45

Cast steel
BR 044

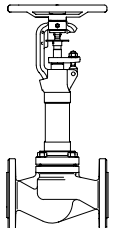

Page 5

**ARI-FABA® LA Straight through
with long bellow & butt weld ends**

- German "TA-Luft" TÜV-Test-No. 088-945053
- TRB 801 No. 45

Forged steel
Cast steel
BR 067

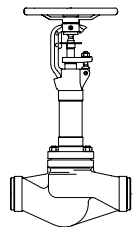

Page 5/6

**ARI-FABA® LA Y-pattern
with long bellow & butt weld ends**

- German "TA-Luft" TÜV-Test-No. 088-945053
- TRB 801 No. 45

Cast steel
BR 068

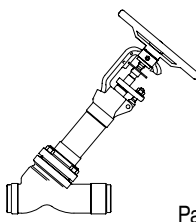

Page 6

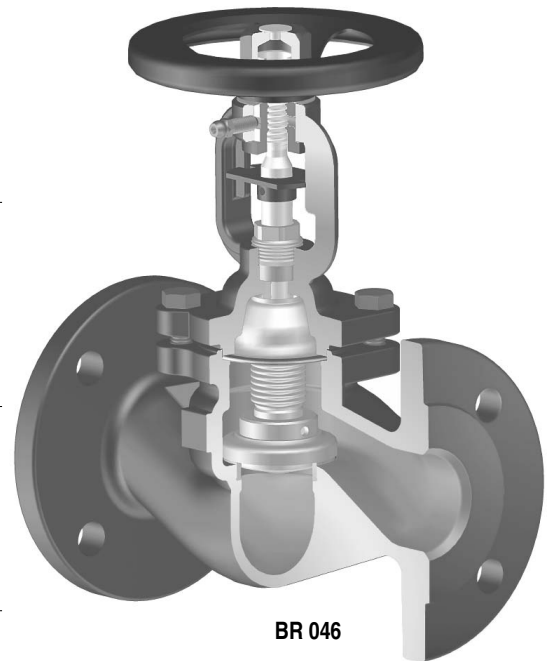

BR 046

Features of FABA® Long Life:

- Double wall bellows seal as standard
- DN 15 - 100 throttling plug as standard
- DN 15 - 80 stem with fine thread as standard
- Lubricating nipple as locking device as standard
- Cast iron variations with nodular iron bonnet as standard
- Maintenance-free
- Heat dissipating bonnet
- Stem with bellows seal
- Secondary sealing: gland packing
- Position indicator as standard
- Non-rising handwheel
- Non-rotation lock for each nominal diameter
- External stem thread
- Stem with roll hardened thread

FABA LA: • Bellows seal out of media flow path

- Favourable zeta-values also for small nominal diameters
- Gland packing sleeve with pivot mounted bolts

For stainless steel refer to data sheet „FABA® LongLife - stainless steel“

For ANSI refer to data sheet „FABA®-ANSI LongLife“

ARI-FABA® Long Life - Stop valve with bellows seal, made of cast iron, nodular iron and cast steel

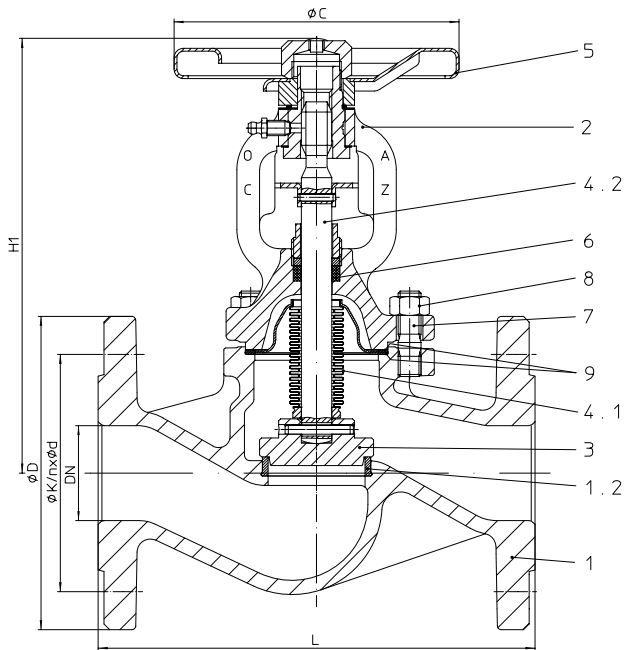

Figure	Nom. pressure	Material	Nom. diameter
12.046	PN 16	EN-JL1040	DN 15-300
22.046	PN 16	EN-JS1049	DN 15-350
Test: DIN-DVGW-Reg. NG-4313AO 0772			
23.046	PN 25	EN-JS1049	DN 15-150
34.046	PN 25	1.0619+N	DN 200-400
Test: TÜ.A/TÜV.AR 186-00 DIN-DVGW-Reg. NG-4314AO 0777			
35.046	PN 40	1.0619+N	DN 15-250
Test: TÜ.A/TÜV.AR 186-00 DIN-DVGW-Reg. NG-4314AO 0778			
Test: German "TA-Luft" TÜV-Test-No. 088-945053			
DN 15 - 100 Throttling plug as standard (for max. permissible Δp refer to annex „Flow diagram“)			

Selection of possible applications:

- Industry
- Vacuum facilities
- Powerstations
- Ammonia
- Flue gas purification plant
- Hot water
- Processing technology
- Heating technology
- Gas supply
- District heating
- Vapour facilities
- Cooling and freezing systems
- Thermal oil applications
- General plant manufacturing
- Recycling facilities
- Steam systems

- other applications on request -

Weights (kg)

Figure-No.	DN	15	20	25	32	40	50	65	80	100	125	150	200	250	300	350	400	500
12.046 / 22.046 / 23.046		3,6	4,3	5,3	6,6	9,2	11,6	15,8	21,8	33,0	54,0	69,0	140,0	240,0	265,0	360,0	--	--
34.046		--	--	--	--	--	--	--	--	--	--	--	147,0	238,0	339,0	570,0	650,0	--
35.046		4,5	4,8	6,2	7,3	10,6	12,6	19,1	26,1	35,0	60,3	88,0	178,0	305,0	--	--	--	--

ARI-FABA® Long Life - Stop valve with bellows seal, made of forged steel

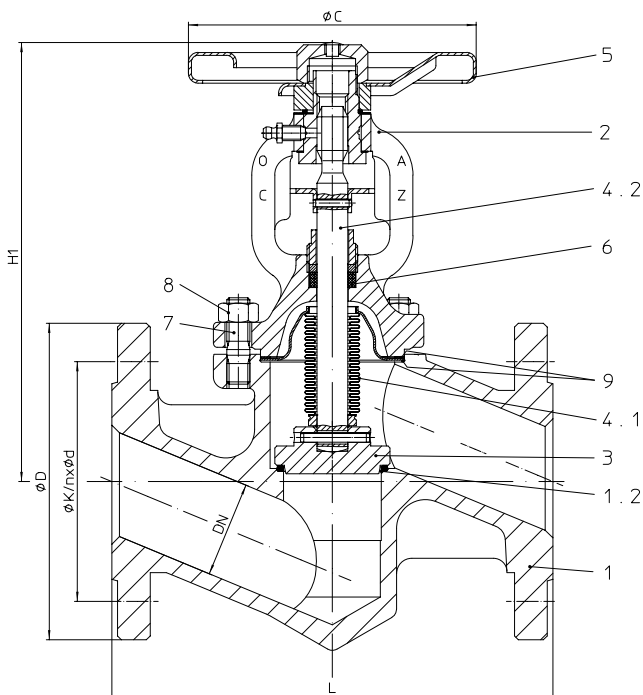

Figure	Nom. pressure	Material	Nom. diameter
45.046	PN 40	1.0460	DN 15-50
for DN >50 refer to Fig. 35.046 (1.0619+N)			
Test: German "TA-Luft" TÜV-Test-No. 088-945053 Test approvals TÜ.A/TÜV.AR.186-00			
DN 15 - 50 Throttling plug as standard (for max. permissible Δp refer to annex „Flow diagram“)			

Selection of possible applications:

- Industry
- Vacuum facilities
- Powerstations
- Ammonia
- Flue gas purification plant
- Hot water
- Processing technology
- Heating technology
- Gas supply
- District heating
- Vapour facilities
- Cooling and freezing systems
- Thermal oil applications
- General plant manufacturing
- Recycling facilities
- Steam systems

- other applications on request -

Weights (kg)

Figure-No.	DN	15	20	25	32	40	50	65	80	100	125	150	200	250	300	350	400	500
45.046		3,8	4,8	5,5	7,0	10,0	12,0	--	--	--	--	--	--	--	--	--	--	--

ARI-FABA® Long Life - Stop valve with bellows seal, made of forged steel

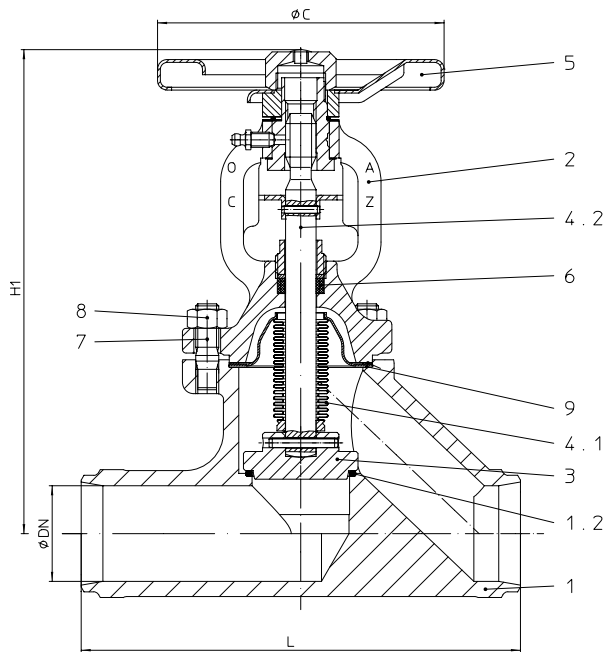

Figure	Nominal pressure	Material	Nominal diameter
45.040	PN 40	1.0460	DN 15-50
	for DN >50 refer to Fig. 35.040 (1.0619+N)		
Butt weld ends acc. to DIN EN 12627 - 4 (refer to page 7)			
Test: TÜ.A/TÜV.AR 186-00 German "TA-Luft" TÜV-Test-No. 088-945053			
DN 15 - 50 Throttling plug as standard (for max. permissible Δp refer to annex „Flow diagram“)			

Selection of possible applications:

- Industry
 - Powerstations
 - Flue gas purification plant
 - Processing technology
 - Gas supply
 - Vapour facilities
 - Thermal oil applications
 - Recycling facilities
 - Vacuum facilities
 - Ammonia
 - Hot water
 - Heating technology
 - District heating
 - Cooling and freezing systems
 - General plant manufacturing
 - Steam systems
- other applications on request -

Weights (kg)

Figure-No.	DN	15	20	25	32	40	50	65	80	100	125	150	200	250	300	350	400	500
45.040		2,6	2,8	3,8	4,2	5,8	8,2	--	--	--	--	--	--	--	--	--	--	--

ARI-FABA® Long Life - Stop valve with bellows seal, made of cast steel

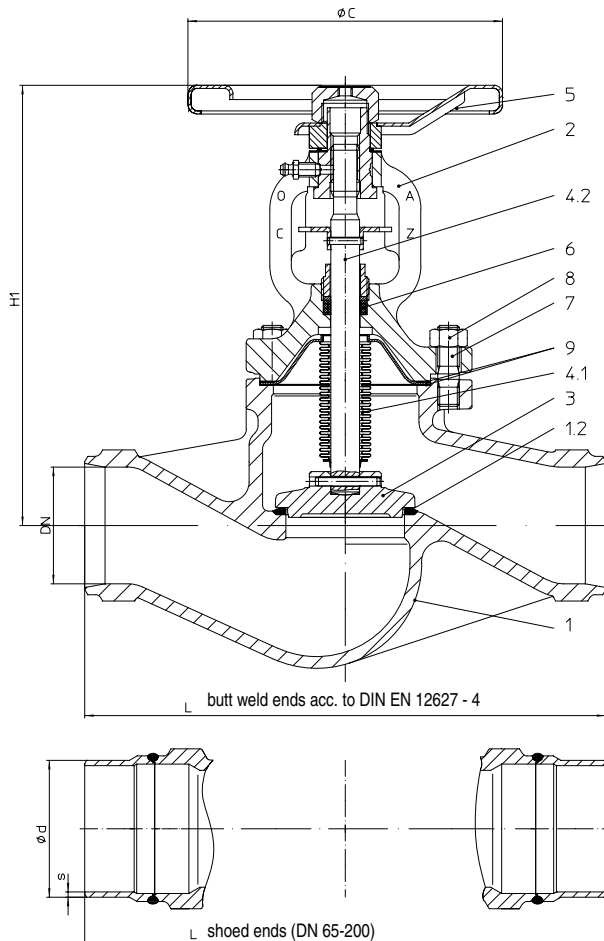

Figure	Nominal press.	Material	Nominal diam.
34.040	PN 25	1.0619+N	DN 200-300
35.040	PN 40	1.0619+N	DN 65-150
Butt weld ends acc. to DIN EN 12627 - 4 (ref. to page 7) alternative: DN 65-200 with shoed ends of P235GH			
Test: TÜ.A/TÜV.AR 186-00 German "TA-Luft" TÜV-Test-No. 088-945053 DIN-DVGW-Reg. NG-4313AO 0777 / 0778			
DN 65 - 100 Throttling plug as standard (for max. permissible Δp refer to annex „Flow diagram“)			

Selection of possible applications:

- Industry
 - Powerstations
 - Flue gas purification plant
 - Processing technology
 - Gas supply
 - Vapour facilities
 - Thermal oil applications
 - Recycling facilities
 - Vacuum facilities
 - Ammonia
 - Hot water
 - Heating technology
 - District heating
 - Cooling and freezing systems
 - General plant manufacturing
 - Steam systems
- other applications on request -

Weights (kg)

Figure-No.	DN	65	80	100	125	150	200	250	300
34.040		--	--	--	--	--	116,0	150,0	250,0
35.040		12,0	16,8	23,6	40,0	56,0	--	--	--

ARI-FABA® Long Life - Stop valve with bellows seal, made of cast steel

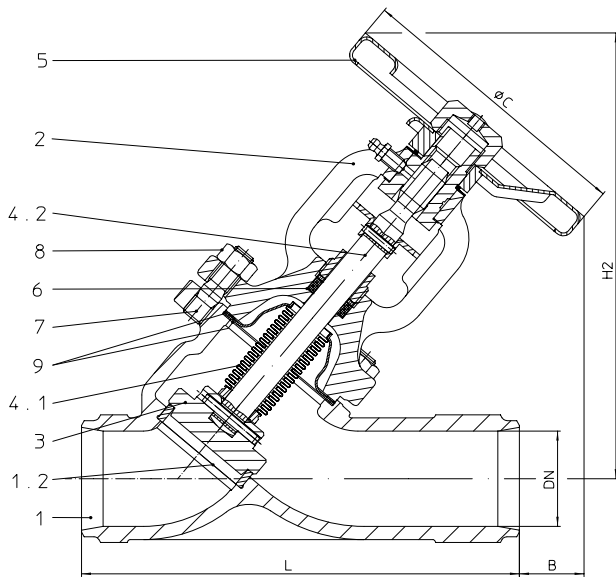

Figure	Nom. pressure	Material	Nom. diameter
34.066	PN 25	1.0619+N	DN 200-300
	Test: DIN-DVGW-Reg. NG-4313AO 0775		
35.066	PN 40	1.0619+N	DN 15-150
	for DN >150 refer to Fig. 35.068		
Test: DIN-DVGW-Reg. NG-4313AO 0776			
Butt weld ends acc. to DIN EN 12627 - 4 (refer to page 7)			
Test: TÜ.A/TÜV.AR 186-00 German "TA-Luft" TÜV-Test-No. 088-945053			
DN 15 - 100 Throttling plug as standard (for max. permissible Δp refer to annex „Flow diagram“)			

Selection of possible applications:

- Industry
- Vacuum facilities
- Powerstations
- Ammonia
- Flue gas purification plant
- Hot water
- Processing technology
- Heating technology
- Gas supply
- District heating
- Vapour facilities
- Cooling and freezing systems
- Thermal oil applications
- General plant manufacturing
- Recycling facilities
- Steam systems

- other applications on request -

Weights (kg)

Figure-No.	DN	15	20	25	32	40	50	65	80	100	125	150	200	250	300	350	400	500
34.066 / 35.066		2,8	3,0	3,4	3,2	4,5	7,3	9,0	11,4	14,3	27,5	44,0	131,0	210,0	230,0	on request		

ARI-FABA® Long Life - Stop valve with bellows seal, made of cast iron, nodular iron and cast steel

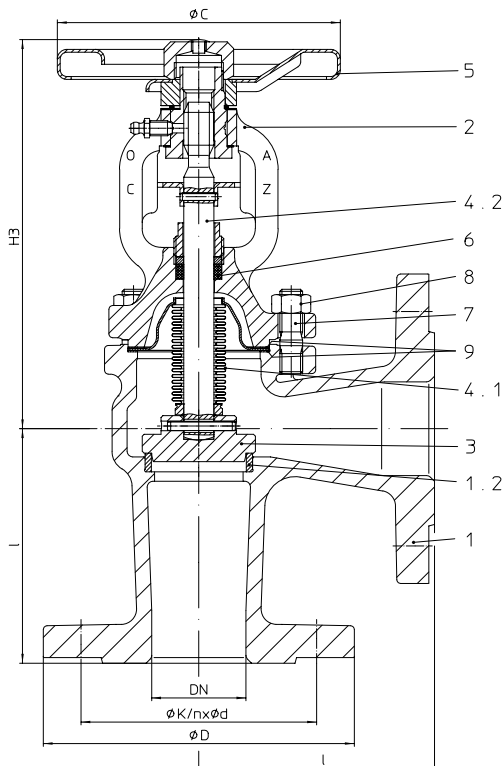

Figure	Nom. pressure	Material	Nom. diameter
12.047	PN 16	EN-JL1040	DN 15-300
22.047	PN 16	EN-JS1049	DN 15-300
	Test: DIN-DVGW-Reg. NG-4313AO 0771		
34.047	PN 25	1.0619+N	DN 15-300
	Test: TÜ.A/TÜV.AR 186-00 DIN-DVGW- NG-4314AO 0773		
35.047	PN 40	1.0619+N	DN 15-150
	Test: TÜ.A/TÜV.AR 186-00 DIN-DVGW-Reg. NG-4314AO 0774		
Test: German "TA-Luft" TÜV-Test-No. 088-945053 (for all Figure-No.)			
DN 15 - 100 Throttling plug as standard (for max. permissible Δp refer to annex „Flow diagram“)			

Selection of possible applications:

- Industry
- Vacuum facilities
- Powerstations
- Ammonia
- Flue gas purification plant
- Hot water
- Processing technology
- Heating technology
- Gas supply
- District heating
- Vapour facilities
- Cooling and freezing systems
- Thermal oil applications
- General plant manufacturing
- Recycling facilities
- Steam systems

- other applications on request -

Weights (kg)

Figure-No.	DN	15	20	25	32	40	50	65	80	100	125	150	200	250	300	350	400	500
12.047 / 22.047		3,7	4,4	5,1	6,5	8,3	11,2	14,6	19,4	29,4	44,0	58,0	99,0	161,0	235,0	--	--	--
34.047		--	--	--	--	--	--	--	--	--	--	--	124,0	153,0	261,0	--	--	--
35.047		4,6	6,4	6,7	7,5	10,1	12,7	17,5	22,0	34,0	49,0	60,0	--	--	--	--	--	--

ARI-FABA®-LA - Stop valve with bellows seal, made of cast steel

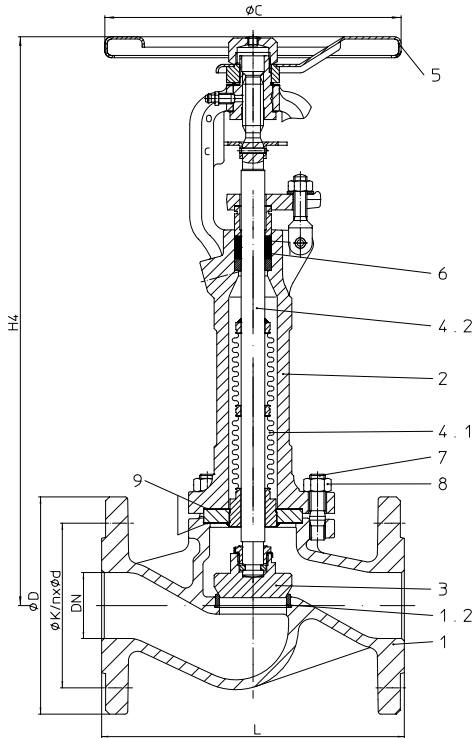

Figure	Nominal pressure	Material	Nominal diameter
34.044	PN 25	1.0619+N	DN 15-400
35.044	PN 40	1.0619+N	DN 15-400

Test: German "TA-Luft" TÜV-Test-No. 088-945053

Selection of possible applications:

- Industry
 - Powerstations
 - Flue gas purification plant
 - Processing technology
 - Gas supply
 - Vapour facilities
 - Thermal oil applications
 - Recycling facilities
 - Vacuum facilities
 - Ammonia
 - Hot water
 - Heating technology
 - District heating
 - Cooling and freezing systems
 - General plant manufacturing
 - Steam systems
- other applications on request -

- Bellows seal out of media flow path. Especially for pulsating, turbulent flow directly behind pumps, elbows, junctions etc.

Weights (kg)

Figure-No.	DN	15	20	25	32	40	50	65	80	100	125	150	200	250	300	350	400	500
34.044 / 35.044		6,1	7,0	8,0	10,0	13,3	16,0	24,0	28,0	42,0	65,0	90,0	170,0	300,0	360,0	410,0	600,0	on requ.

ARI-FABA®-LA - Stop valve with bellows seal, made of forged steel

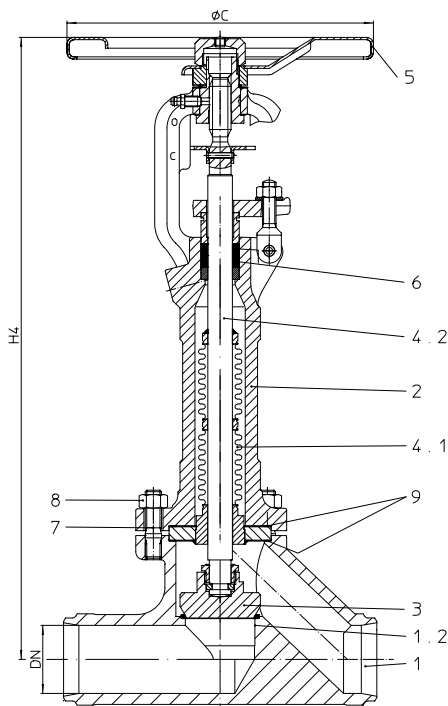

Figure	Nominal pressure	Material	Nominal diameter
45.067	PN 40	1.0460	DN 15-50

Butt weld ends acc. to DIN EN 12627 - 4 (refer to page 7)

Test: German "TA-Luft" TÜV-Test-No. 088-945053

Selection of possible applications:

- Industry
 - Powerstations
 - Flue gas purification plant
 - Processing technology
 - Gas supply
 - Vapour facilities
 - Thermal oil applications
 - Recycling facilities
 - Vacuum facilities
 - Ammonia
 - Hot water
 - Heating technology
 - District heating
 - Cooling and freezing systems
 - General plant manufacturing
 - Steam systems
- other applications on request -

- Bellows seal out of media flow path. Especially for pulsating, turbulent flow directly behind pumps, elbows, junctions etc.

Weights (kg)

Figure-No.	DN	15	20	25	32	40	50	65	80	100	125	150	200	250	300	350	400	500
45.067		4,7	5,1	6,0	7,0	9,0	11,5	--	--	--	--	--	--	--	--	--	--	--

ARI-FABA®-LA - Stop valve with bellows seal, made of cast steel

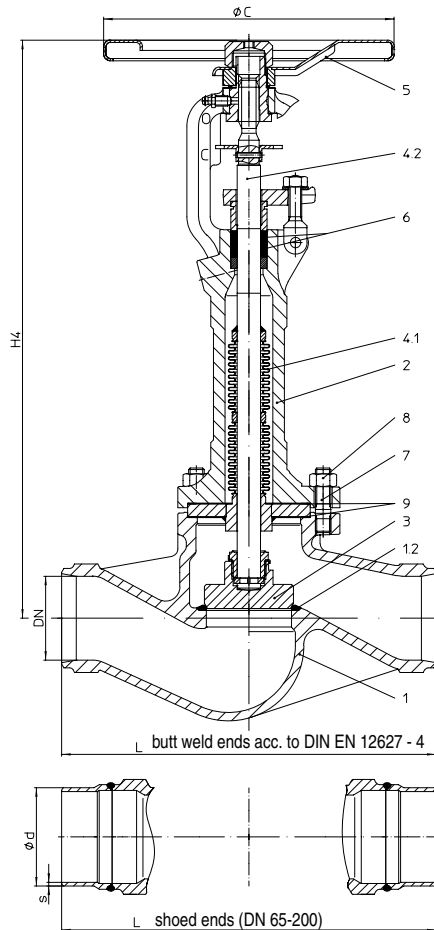

Figure	Nominal pressure	Material	Nominal diameter
35.067	PN 40	1.0619+N	DN 65-300
Butt weld ends acc. to DIN EN 12627 - 4 (ref. to page 7) alternative: DN 65-200 with shoed ends of P235GH			
Test: German "TA-Luft" TÜV-Test-No. 088-945053			

Selection of possible applications:

- Industry
 - Powerstations
 - Flue gas purification plant
 - Processing technology
 - Gas supply
 - Vapour facilities
 - Thermal oil applications
 - Recycling facilities
 - Vacuum facilities
 - Ammonia
 - Hot water
 - Heating technology
 - District heating
 - Cooling and freezing systems
 - General plant manufacturing
 - Steam systems
- other applications on request -

- Bellows seal out of media flow path. Especially for pulsating, turbulent flow directly behind pumps, elbows, junctions etc.

Weights (kg)

Figure-No.	DN	65	80	100	125	150	200	250	300
35.067		18,0	22,0	32,0	50,0	70,0	130,0	245,0	290,0

ARI-FABA®-LA - Stop valve with bellows seal, made of cast steel

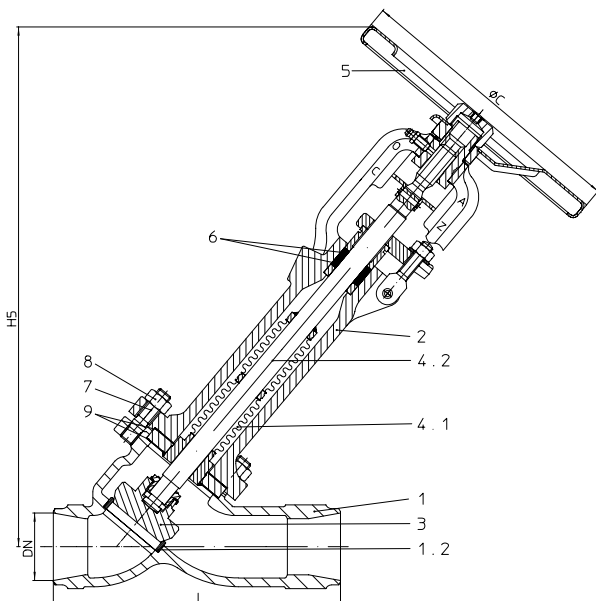

Figure	Nominal pressure	Material	Nominal diameter
35.068	PN 25	1.0619+N	DN 200-300
for DN <200 refer to Fig. 35.066			
Butt weld ends acc. to DIN EN 12627 - 4 (refer to page 7)			
Test: German "TA-Luft" TÜV-Test-No. 088-945053			

Selection of possible applications:

- Industry
 - Powerstations
 - Flue gas purification plant
 - Processing technology
 - Gas supply
 - Vapour facilities
 - Thermal oil applications
 - Recycling facilities
 - Vacuum facilities
 - Ammonia
 - Hot water
 - Heating technology
 - District heating
 - Cooling and freezing systems
 - General plant manufacturing
 - Steam systems
- other applications on request -

- Bellows seal out of media flow path. Especially for pulsating, turbulent flow directly behind pumps, elbows, junctions etc.

Weights (kg)

Figure-No.	DN	15	20	25	32	40	50	65	80	100	125	150	200	250	300	350	400	500
35.068		--	--	--	--	--	--	--	--	--	--	--	110,0	245,0	290,0	--	--	--

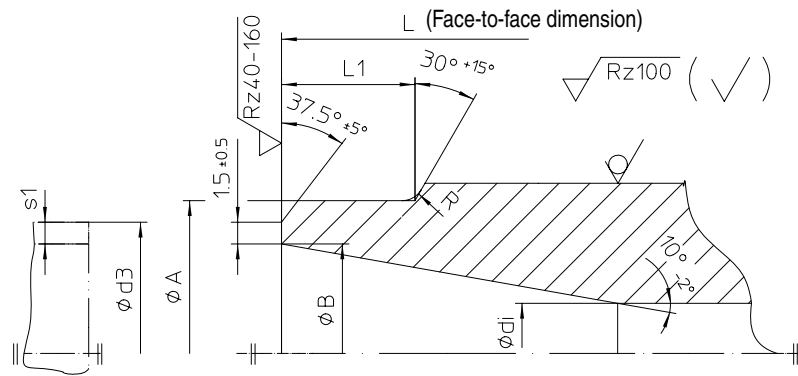

Edge shaping according to DIN EN 25817

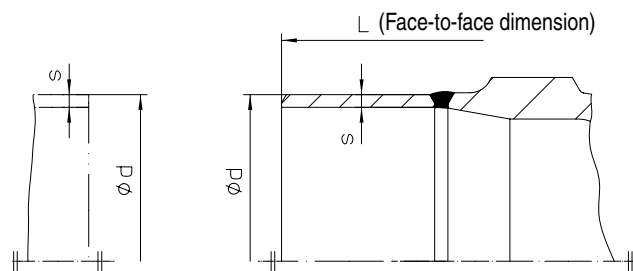

DN	L	Butt weld ends acc. to DIN EN12627 - 4						Shoed ends of P235GH Pipe connection ≙ welding neck flanges	
		Ø A	Ø B	Ø di	R	L1	Pipe Ød3 x s1	Ø d	s
15	130	22	17,3	15	3	10	21,3 x 2,0	--	--
20	150	28	22,3	20	3	10	26,9 x 2,3	--	--
25	160	35	28,5	25	3	10	33,7 x 2,6	--	--
32	180	44	37,2	32	3	10	42,4 x 2,6	--	--
40	200	50	43,1	40	3	10	48,3 x 2,6	--	--
50	230	62	53,9	50	3	10	60,3 x 3,2	--	--
65	290	77	68,9	65	3	10	76,1 x 3,6	76,1	2,9
80	310	91	80,9	80	3	12	88,9 x 4,0	88,9	3,2
100	350	117	104,3	100	3	14	114,3 x 5,0	114,3	3,6
125	400	144	130,7	125	3	18	139,7 x 4,5	139,7	4,0
150	480	172	157,1	150	3	20	168,3 x 5,6	168,3	4,5
200	600	223	204,9	200	5	20	219,1 x 7,1	219,1	6,3
250	730	278	257,0	250	5	25	273,0 x 8,0	--	--
300	850	329	307,9	300	5	33	323,9 x 8,0	--	--

Face-to-face dimension according to DIN EN 12982 ETE-1 (DIN 3202 T2)

Butt weld ends according to DIN EN12627 - 4 (DIN 3239 T1, form 2)

Weld joint according to DIN EN 29692 code numer 1.3.3 (DIN 2559 T1, code number 22)

The material used for ARI valves with butt weld ends is: GP240GH+N, 1.0619+N according to DIN EN 10213-1-2, P250GH, 1.0460 according to DIN EN 10222-2.

The material used for ARI valves with shoed ends (DN 65-200) P235GH according to DIN EN 10216-2.

Based on our experience we recommend electric welding process for connecting valves or strainers with tubes or with each other.

Lime based electrodes with an appropriate composite material should be used as filler material for welding.

Gas welding should be avoided.

Due to the different material composition and material thickness of valves and tubes, gas welding is more susceptible to produce faults than electric welding (hardness cracks, coarse-grained structure).

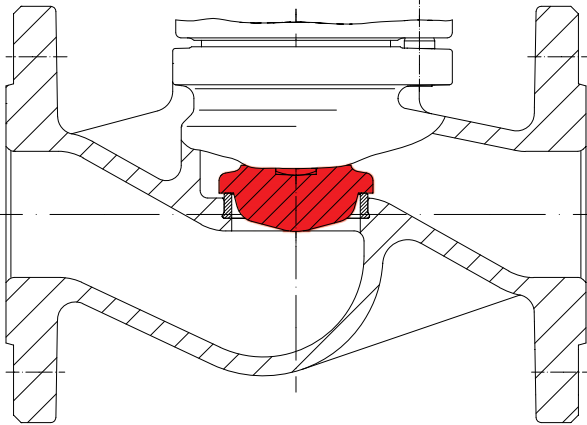

Regulating plug

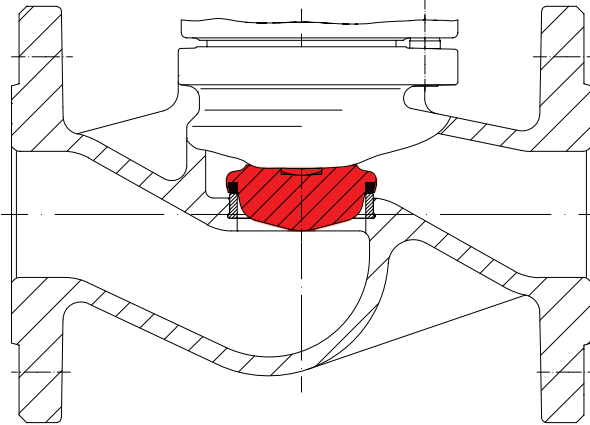

Regulating plug with soft seal PTFE + 25% carbon
Max. operating temperature 200 °C

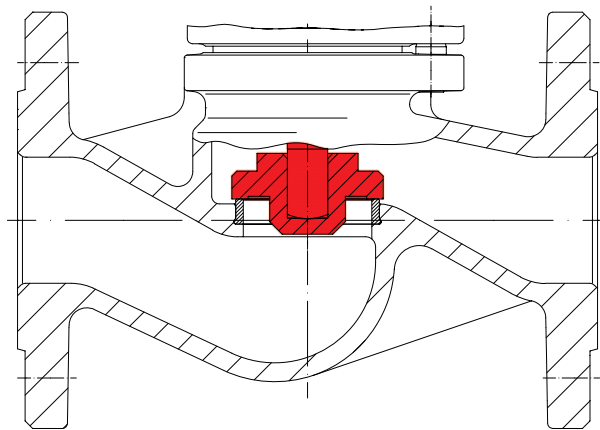

Screw down non-return plug - max. differential pressure, refer to table of pressure balancing plugs (page 9)
Set pressure 0,05 bar
Important: Installation of the valve only in horizontal pipe runs with vertical stem.

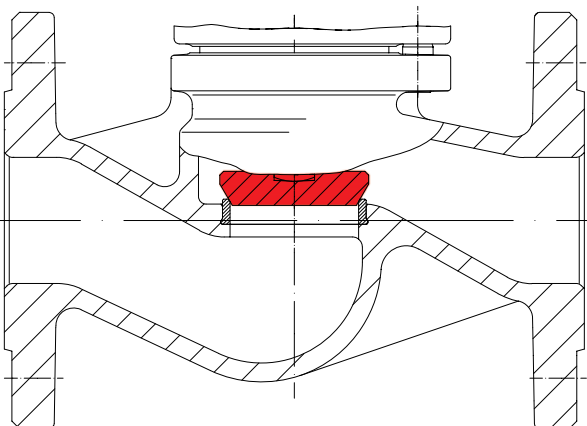

Plug with marginal seat

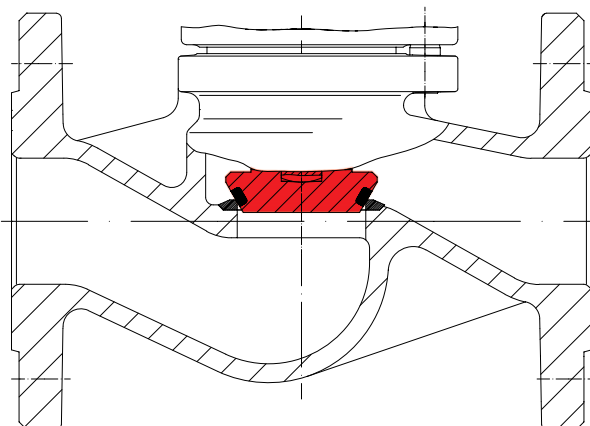

Plug with marginal seat; stellited seat and plug

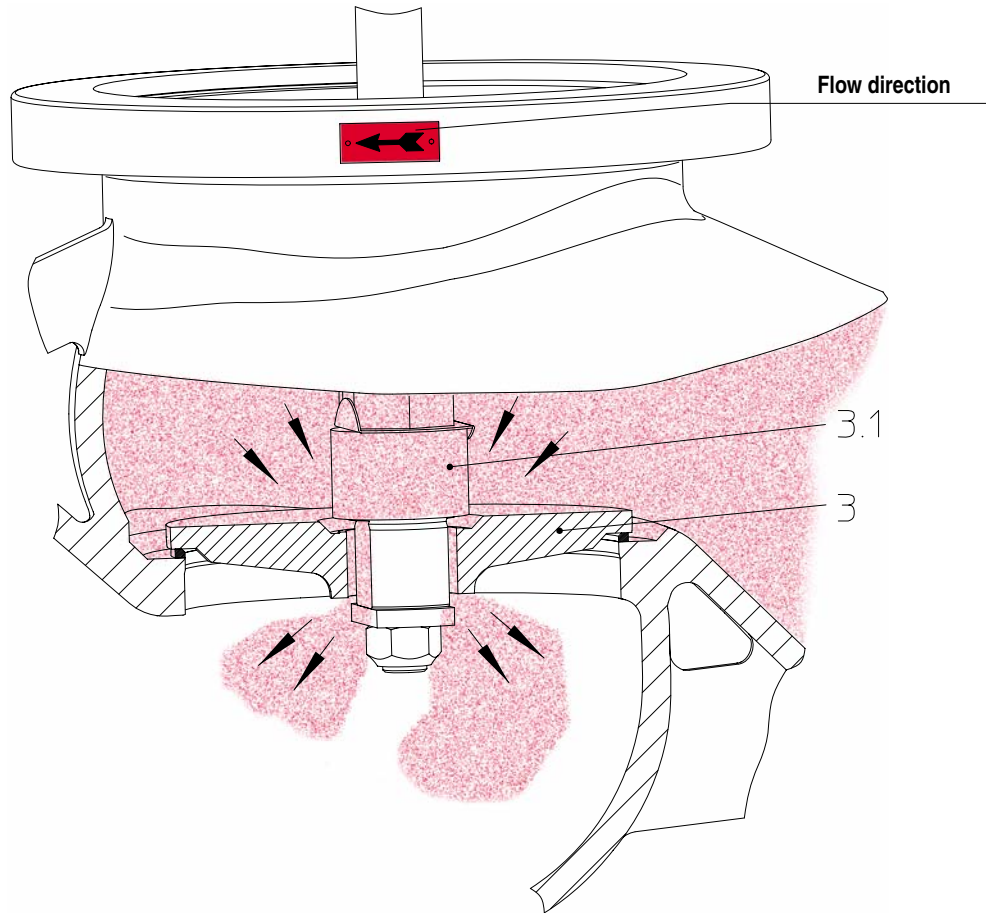

Valves with **balancing plugs** have to be installed with medium flowing over the plug (3) as indicated by flow direction arrow on valve body.

Working principles:

When the valve is closed, anticlockwise rotation of the hand wheel lifts the pilot plug (3.1) off the larger balancing plug (3). This allows the medium to pass through the plug and equalizes the pressure of the medium under the plug (3). After the pressures have been equalized within the values stated in the table, the valve can be opened by turning the valve further with normal manual force.

Balancing plugs are fully effective only in closed systems.

The pressures of the medium on either side of the plug cannot be equalized if the medium is discharged into "open air".

A bypass line or some other arrangement is necessary if too much time is required for pressure equalization owing to the volume in the piping system.

ARI-stop valves with differential pressures exceeding the following pressures, have to be fitted with pressure balancing plugs:

Balancing plug	DN	125	150	200	250	300	350	400	500
Differential pressure	Δp	25 bar	21 bar	14 bar	9 bar	6 bar	4,5 bar	3,5 bar	1,5 bar

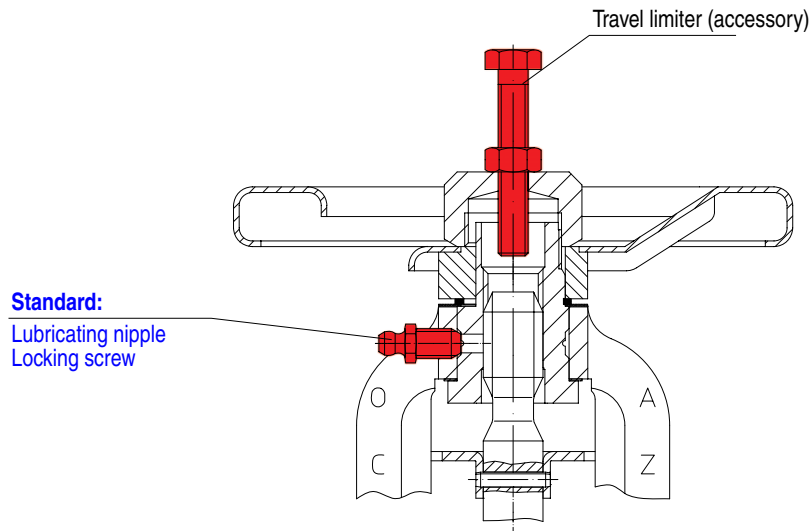

Functions:

1. Lubrication
(Prevents the handwheel jamming.)
2. Locking screw
(Allows valve to be locked-off at desired travel.)

Accessories are not included !	
DN	Hexagon screw
15- 80	M8 x 55
100	M12 x 70
125-150	M12 x 80
200	M12 x 100
250-300	M12 x 120
350-400	M16 x 160

Lubricating nipple / locking device / travel limiter

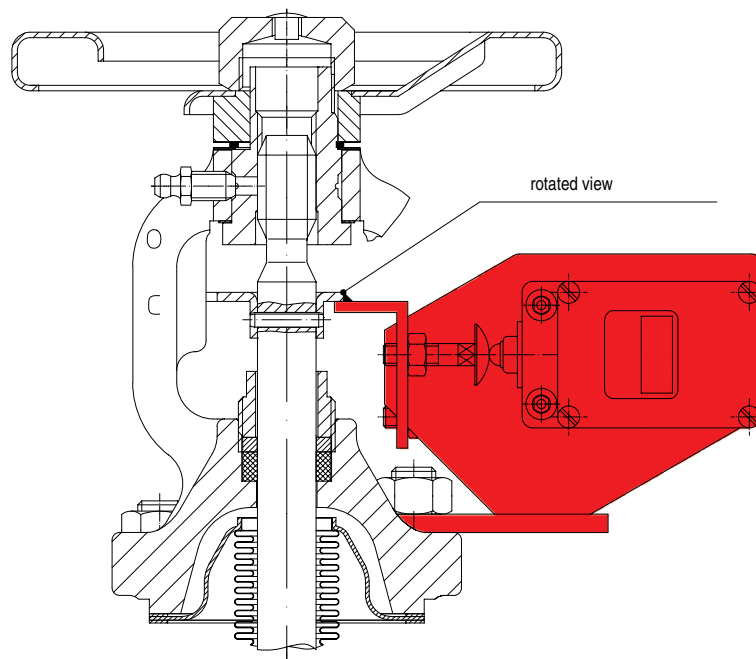

Limit switch

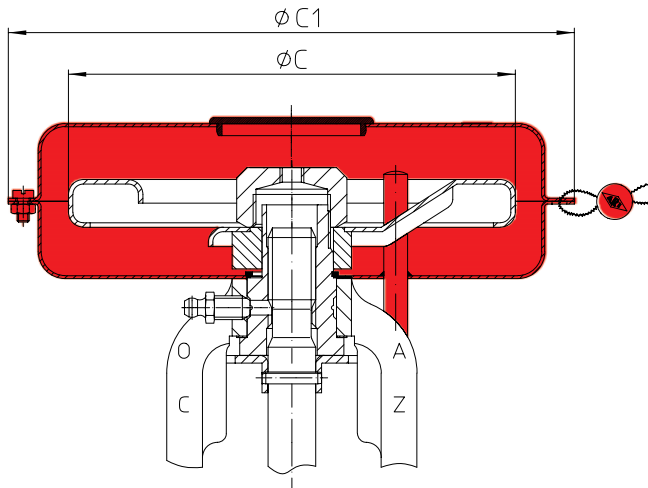

Hood size	DN	$\varnothing C$ (mm)	$\varnothing C1$ (mm)
I	15- 32	126	170
II	40- 80	150	190
III	100-150	225	330

Handwheel- $\varnothing C$ from DN 65 reduced !

Hood valve (tamper resistant handwheel cover)

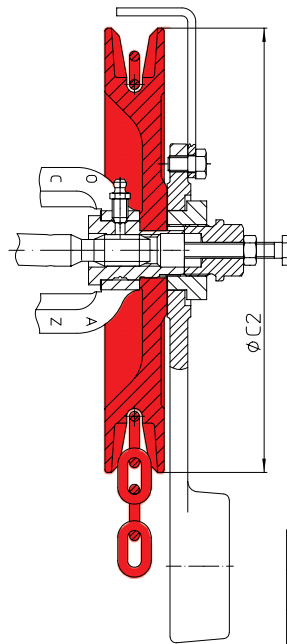

DN	$\varnothing C2$ (mm)	Weight (kg)
15- 32	180	2.5
40- 80	220	7
100-150	260	8.9
200-400	300	11

Chain wheel

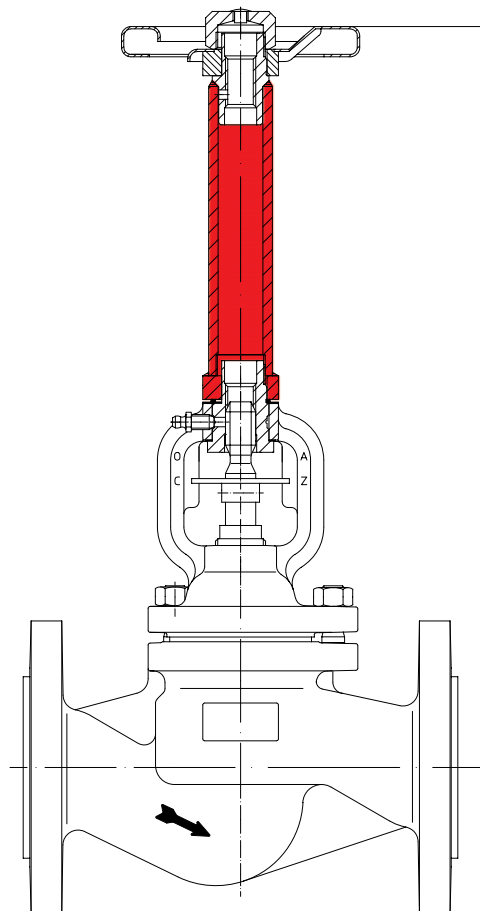

Stem extension (please specify the height in your order)

Dimensions, Kvs- and Zeta-values

DN	L	I	H1		H2		H3	H4	H5	ØC			B			Travel		Kvs-values			Zeta-values		
			with casted bodies	with forged bodies	with casted bodies	with forged bodies				PN 16 PN 25	PN 40	FABA LA	FABA with casted bodies	FABA with forged bodies	FABA LA	FABA	FABA LA	straight through	with forged bodies	Y- pattern	straight through	with forged bodies	Y- pattern
15	130	90	205	215	195	205	190	325	--	126	126	175	85	95	--	6	7	4,7	3,3	5,7	3,5	7,2	2,5
20	150	95	205	215	195	205	190	325	--	126	126	175	65	75	--	6	7	7,4	5,8	6,8	4,5	7,3	5,5
25	160	100	210	225	205	210	195	335	--	126	126	175	65	75	--	8	10	11,2	9,2	12,7	4,8	7,1	3,9
32	180	105	210	230	205	210	195	335	--	126	126	175	50	55	--	8	10	18,3	15,0	16,8	4,8	7,2	5,9
40	200	115	225	250	235	235	210	430	--	150	150	225	60	65	--	13	17	29,3	23,3	35,8	4,6	7,3	3,2
50	230	125	230	255	235	235	210	435	--	150	150	225	35	35	--	13	17	44,2	36,0	47,7	4,9	7,4	4,4
65	290	145	245	--	265	--	220	450	--	175	175	225	10	--	--	16	20	73,2	--	77	5,1	--	4,8
80	310	155	265	--	295	--	235	460	--	175	225	225	45	--	--	20	20	112,2	--	107	5,0	--	5,8
100	350	175	365	--	380	--	325	620	--	225	300	300	90	--	--	25	36	173	--	174	5,1	--	5,3
125	400	200	395	--	415	--	345	645	--	300	300	300	60	--	--	32	40	288	--	279	4,5	--	5,0
150	480	225	425	--	480	--	370	680	--	400	400	400	50	--	--	40	40	410	--	406	4,6	--	4,2
200	600	275	550	--	615	--	485	830	805	520	520	520	110	--	255	50	50	725	--	709	4,6	--	5,1
250	730	325	720	--	740	--	615	915	910	520	--	520	100	--	235	70	65	1145	--	1253	4,5	--	4,0
300	850	375	775	--	795	--	665	955	1010	520	--	520	45	--	220	80	75	1635	--	1655	4,6	--	4,7
350	980	425	975	--	--	--	855	1255	--	640	--	520	--	--	--	90	90	2220	--	--	4,7	--	--
400	1100	475	1015	--	--	--	890	1270	--	640	--	520	--	--	--	100	100	3180	--	--	3,9	--	--
500	1350*	on request	--	--	--	--	--	1380	--	--	--	640	--	--	--	--	115	4530	--	--	4,6	--	--

Zeta-value ... range of tolerance for Kvs-values acc. to DIN EN 60534.

* Face-to-face dimension acc. to ARI-works standard

Dimensions of flanges refer to page 13 or ARI quick reference slide chart (available on request).

- Globe valves with flanges:** Face-to-face dimension FTF series 1 according to DIN EN 558-1 (DIN 3202-1 series F1)
Angle pattern globe valves with flanges: Face-to-face dimension CTF series 8 according to DIN EN 558-1 (DIN 3202-1 series F32)
Globe valves with butt weld ends: Face-to-face dimension ETE series 1 according to DIN EN 12982 (DIN 3202-2 series S7)

Figure	12.046; 12.047	22. / 23.046; 22. / 23.047	34. / 35.040; 34. / 35.044; 34. / 35.046; 34. / 35.047; 34. / 35.066; 35.067; 35.068	45.040; 45.046 45.067	
Pos.	Description				
Material, Material-No.					
1	Body	EN-JL1040, EN-GJL-250	EN-JS1049, EN-GJS-400-18U-LT	GP240GH+N, 1.0619+N	P250GH, 1.0460
1.2	Seat	X20Cr13+QT, 1.4021+QT		DN ≤ 50: X20Cr13+QT, 1.4021+QT; DN > 50: G19 9 Nb Si, 1.4551	G19 9 Nb Si, 1.4551
2	Bonnet	EN-JS1049, EN-GJS-400-18U-LT	EN-JS1049, EN-GJS-400-18U-LT	DN ≤ 80: P250GH, 1.0460 DN > 80: GP240GH+N, 1.0619+N	P250GH, 1.0460
3	Plug	DN ≤ 200: X20Cr13+QT, 1.4021+QT DN > 200: P265 GH DIN EN 10028-2, / G19 9 Nb Si, 1.4551			X20Cr13+QT, 1.4021+QT
4.1	Bellow	X6CrNiMoTi17-12-2, 1.4571			
4.2	Stem	X20Cr13+QT, 1.4021+QT at FABA LA: X6CrNiTi18-10, 1.4541			
5	Handwheel	DN ≤ 125: St coated DN > 125: EN-JL1040, EN-GJL-250 coated			Fe P01, 1.0330 coated
6	Gland packing	Pure graphite			
7	Hex. screws / Studs	5.6	25CrMo4, 1.7218		
8	Hexagon nuts	--	C35E, 1.1181		
9	Gasket	CrNi laminated both sides with pure graphite			

Information / restriction of technical rules to be observed!

Operating instructions can be ordered on request by phone (+49 52 07) 994-0 or fax (+49 52 07) 994-158 or 159.

ARI-Valves of cast iron are not allowed to be operated in systems acc. to TRD 110.

A production allowance acc. to TRB 801 No. 45 exists. (acc. to TRB 801 No. 45 cast iron is not allowed.)

The engineer, designing a system or a plant, is responsible for the selection of the correct valve.

ARI-FABA flow diagrams refer to technical annex

Leakage rate according to DIN 3230-3 (leakage rate 1)

Alternative description DIN 3356 „valves“

Pressure-temperature-ratings

Flangeholes / -thickness tol. acc. to DIN 2533 / DIN 2544 / DIN 2545

acc. to DIN EN 1092-2		Temperature								
Material	PN	-60°C up to <-10°C*	-10°C up to 120°C	150°C	200°C	250°C	300°C	350°C	400°C	450°C
EN-JL1040	16	---	16 bar	14,4 bar	12,8 bar	11,2 bar	9,6 bar	---	---	---
EN-JS1049	16	on request	16 bar	15,5 bar	14,7 bar	13,9 bar	12,8 bar	11,2 bar	---	---
	25	on request	25 bar	24,3 bar	23 bar	21,8 bar	20 bar	17,5 bar	---	---
	40	on request	40 bar	38,8 bar	36,8 bar	34,8 bar	32 bar	28 bar	---	---

acc. to DIN EN 1092-1		Temperature									
Material	PN	-60°C up to <-10°C*	-10°C up to 50°C	100°C	150°C	200°C	250°C	300°C	350°C	400°C	450°C
1.0619+N	25	18,7 bar	25 bar	23,3 bar	21,7 bar	19,4 bar	17,8 bar	16,1 bar	15 bar	14,4 bar	13,9 bar
	40	30 bar	40 bar	37,3 bar	34,7 bar	30,2 bar	28,4 bar	25,8 bar	24 bar	23,1 bar	22,2 bar
1.0460	25	18,7 bar	25 bar	23,3 bar	21,7 bar	19,4 bar	17,8 bar	16,1 bar	15 bar	14,4 bar	10 bar
	40	30 bar	40 bar	37,3 bar	34,7 bar	30,2 bar	28,4 bar	25,8 bar	24 bar	23,1 bar	16 bar

Intermediate values for max. permissible operational pressures can be determined by linear interpolation of the given temperature / pressure chart.

* Studs and nuts made of A4-70 (at temperatures below -10°C)

Flange dimensions

DN	PN 6			PN 16			PN 25			PN 40		
	Ø D	Ø K	n x Ø d1	Ø D	Ø K	n x Ø d1	Ø D	Ø K	n x Ø d1	Ø D	Ø K	n x Ø d1
15	80	55	4 x 11	95	65	4 x 14	95	65	4 x 14	95	65	4 x 14
20	90	65	4 x 11	105	75	4 x 14	105	75	4 x 14	105	75	4 x 14
25	100	75	4 x 11	115	85	4 x 14	115	85	4 x 14	115	85	4 x 14
32	120	90	4 x 14	140	100	4 x 18	140	100	4 x 18	140	100	4 x 18
40	130	100	4 x 14	150	110	4 x 18	150	110	4 x 18	150	110	4 x 18
50	140	110	4 x 14	165	125	4 x 18	165	125	4 x 18	165	125	4 x 18
65	160	130	4 x 14	185	145	4 x 18	185	145	8 x 18	185	145	8 x 18
80	190	150	4 x 18	200	160	8 x 18	200	160	8 x 18	200	160	8 x 18
100	210	170	4 x 18	220	180	8 x 18	235	190	8 x 22	235	190	8 x 22
125	240	200	8 x 18	250	210	8 x 18	270	220	8 x 26	270	220	8 x 26
150	265	225	8 x 18	285	240	8 x 22	300	250	8 x 26	300	250	8 x 26
200	320	280	8 x 18	340	295	12 x 22	360	310	12 x 26	375	320	12 x 30
250	---	---	---	405	355	12 x 26	425	370	12 x 30	450	385	12 x 33
300	---	---	---	460	410	12 x 26	485	430	16 x 30	515	450	16 x 33
350	---	---	---	520	470	16 x 26	555	490	16 x 33	580	510	16 x 36
400	---	---	---	580	525	16 x 30	620	550	16 x 36	660	585	16 x 39
500	---	---	---	715	650	20 x 33	730	660	20 x 36	755	670	20 x 42

Butt weld ends according to DIN EN 12627 - 4

Please indicate when ordering:

1. Figure-No.
2. Nominal pressure (PN)
3. Nominal diameter (DN)
4. Special design / accessories

Example:

Figure 35.046; nominal pressure PN 40; nominal diameter DN 100.

Dimensions in mm Weights in kg $1 \text{ bar} \triangleq 10^5 \text{ Pa} \triangleq 0,1 \text{ MPa}$ Kvs in m ³ /h $1 \text{Kvs} \triangleq 1,16 \text{ Cv (US)}$
--



Technology for the Future.
GERMAN QUALITY VALVES

ARI-Armaturen Albert Richter GmbH & Co. KG, D-33756 Schloß Holte-Stukenbrock,
Tel. +49 52 07 / 994-0, Telefax +49 52 07 / 994-158 or 159 Internet: <http://www.ari-armaturen.com> E-mail: info.vertrieb@ari-armaturen.com